

CLEMCO®

Classic *Blast Machines*



The Performance System

Classic Clemco – Tough, Reliable, Quality Blast Machines

Semi-elliptical head for larger storage of abrasive.

Urethane-coated pop-up valve with external sleeve for long life and fast pressurization.

Large 6" x 8" inspection door for easy access to inside.

Heavy-gauge construction pressure vessel fabricated for rugged field service. Built to ASME standards. Most models registered in most Canadian provinces.

Conical 35° bottom ensures total use of abrasive and uninterrupted abrasive flow.

45° abrasive flow into air stream – the natural way to uniformly mix air and abrasive. Eliminates premature wear found in 90° systems. A tough stainless steel plate meters precisely. Clean-out provides access to foreign matter.



Self-cleaning exhaust muffler greatly reduces bleed-off noise.

Pop-up valve umbrella (optional) relieves load pressure, when hopper is in place.

Fast, safe TLR remote controls with solid brass valves built for years of dependability.

Chrome-plated forged brass ball valve with brass body for durability and long service life.

Flexible pusher line guarantees air flow without pressure loss caused by elbows; and eases valve replacement.

Built to offer years of reliable service.

U.S. Standard Compressed Air and Abrasive Consumption

Nozzle Orifice	Pressure at the Nozzle (psi)								Air (in cfm) Abrasive & HP requirements
	50	60	70	80	90	100	125	140	
No. 2 (1/8")	11	13	15	17	18.5	20	25	28	Air (cfm)
	.67	.77	.88	1.01	1.12	1.23	1.52	1.70	Abrasive (cu.ft./hr & Lbs/hr)
	67	77	88	101	112	123	152	170	Compressor hp
	2.5	3	3.5	4	4.5	5	5.5	6.2	
No. 3 (3/16")	26	30	33	38	41	45	55	62	Air (cfm)
	1.50	1.71	1.96	2.16	2.38	2.64	3.19	3.57	Abrasive (cu.ft./hr & Lbs/hr)
	150	171	196	216	238	264	319	357	Compressor hp
	6	7	8	9	10	10	12	13	
No. 4 (1/4")	47	54	61	68	74	81	98	110	Air (cfm)
	2.68	3.12	3.54	4.08	4.48	4.94	6.08	6.81	Abrasive (cu.ft./hr & Lbs/hr)
	268	312	354	408	448	494	608	681	Compressor hp
	11	12	14	16	17	18	22	25	
No. 5 (5/16")	77	89	101	113	126	137	168	188	Air (cfm)
	4.68	5.34	6.04	6.72	7.40	8.12	9.82	11.0	Abrasive (cu.ft./hr & Lbs/hr)
	468	534	604	672	740	812	982	1100	Compressor hp
	18	20	23	26	28	31	37	41	
No. 6 (3/8")	108	126	143	161	173	196	237	265	Air (cfm)
	6.68	7.64	8.64	9.60	10.52	11.52	13.93	15.60	Abrasive (cu.ft./hr & Lbs/hr)
	668	764	864	960	1052	1152	1393	1560	Compressor hp
	24	28	32	36	39	44	52	58	
No. 7 (7/16")	147	170	194	217	240	254	314	352	Air (cfm)
	8.96	10.32	11.76	13.12	14.48	15.84	19.31	21.63	Abrasive (cu.ft./hr & Lbs/hr)
	896	1032	1176	1312	1448	1584	1931	2163	Compressor hp
	33	38	44	49	54	57	69	77	
No. 8 (1/2")	195	224	252	280	309	338	409	458	Air (cfm)
	11.60	13.36	15.12	16.80	18.56	20.24	24.59	27.54	Abrasive (cu.ft./hr & Lbs/hr)
	1160	1336	1512	1680	1856	2024	2459	2754	Compressor hp
	44	50	56	63	69	75	90	101	

Consumption rates are based on abrasives that weigh 100 pounds per cubic foot

CLEMCO ABRASIVE METERING VALVES

Application Guide

Model/Description	Standard Equipment on:	Stock No.	Manual or Manual orPneumatic	Remote Control Type	Applications (abrasives/media)
MSV	1/2 and 1 cuft Classic machines	01247	Manual	Pressure-Release	Expendable mineral and slag abrasives; not recommended for use with fine mesh media or glass bead
LPV	Lo-Pot machines	05680	Manual	Pressure-Release	Expendable mineral and slag abrasives
FSV	Classic blast machines, 2 cuft and larger	02427	Manual	Pressure-Release	Expendable mineral and slag abrasives; not suitable for metallic media
Quantum	Contractor and Classic machines, 2 cuft and larger	22845	Manual	Pressure-Release	All common abrasives: mineral, slag, or metallic
Auto Quantum	Contractor and Classic pressure-hold remotes or ACS	24447	Pneumatic	Pressure-hold or pressure-release and abrasive cut-off system	All common abrasives: mineral, slag, or metallic; requires 80 psi to fully open plunger
Sentinel	Classic machines with pressure-hold remotes or ACS; industrial blast machines 2 cuft and larger	20508	Pneumatic	Pressure-hold or pressure-release and abrasive cut-off system	ACS applications: all media; abrasives coarser than 50 mesh; requires 80 psi to fully open plunger

Metering Valves – *Precise Abrasive Metering*

One of the most important features of the blast machine is the abrasive metering valve. Selecting the right valve for your application is the key to productivity and efficiency. The FSV, Quantum, and Sentinel valves are designed to feed abrasive into the air stream at 45 degrees. This design feature eliminates turbulence, minimizes wear on fittings, and ensures smooth, consistent flow.

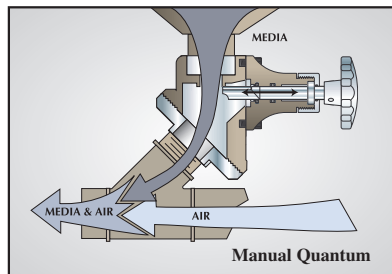

The Quantum valve handles all types of media; minerals, slags, and metallic. Its design allows for precise metering and easy maintenance. The Quantum fits machines from 2-cubic feet to 20-cubic feet capacity.

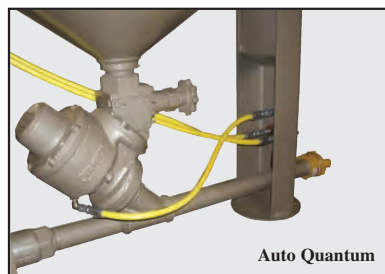

The Auto Quantum is used for pressure-hold systems and pressure-release systems with abrasive cut-off. Abrasive cut-off permits shutting off abrasive to blow down the surface with air. Available in both pneumatic and electric.

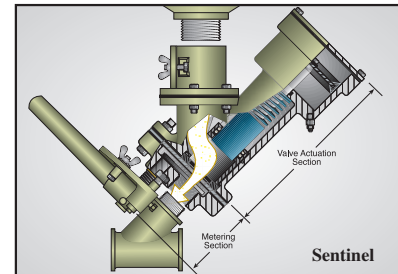

The Sentinel valve features abrasive cut-off allowing the operator to shut off abrasive and blow off the surface with air after blasting. The Sentinel is used for pressure-hold and pressure-release systems, both pneumatic or electric.

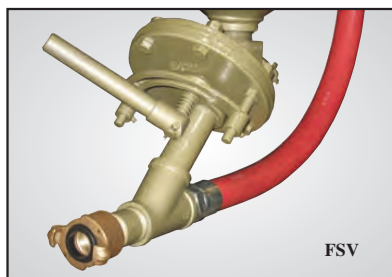

The FSV, an original Clemco design, is the tried-and-true work horse of the industry. It is among the most imitated Clemco components. It is standard on machines from 2-cubic feet to 20-cubic feet capacity.

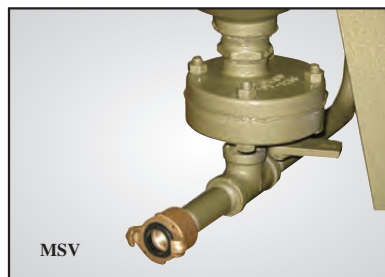

The MSV is a manual valve suited for expendable media; it is used on our 1/2- and 1-cubic foot machines.

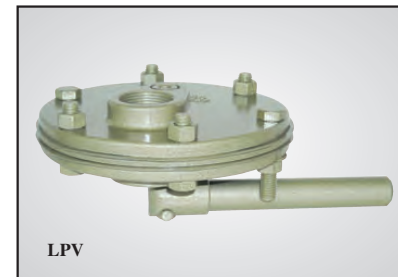

The LPV is a low-profile valve for mineral and slag abrasives; it is used on Lo-Pots.

CLEMCO Classic

Blast Machine Systems

Rugged, Reliable, Proven

More than fifty years of reliable field service have made Clemco blast machines the preferred equipment for industrial blasting and painting contractors.

Clemco machines are built tough to endure real world use. With wear-parts positioned for quick replacement, Clemco blast machines virtually eliminate downtime, so they spend more time at the job site; less time in the shop.

Choose from 1/2-cu. ft. to 20-cu. ft. capacity, in portable or stationary models — blast machine only or machine system.

Take the guesswork out of buying a blast machine by ordering a complete system, which includes the blast machine, remote controls, nozzle, couplings, blast hose, Apollo helmet, air filter, and spare parts — everything but the compressed-air components and abrasive.

BLAST MACHINE CONSTRUCTION

- Pressure vessels built to ASME code. Most models registered in most Canadian provinces.
- Concave head stores abrasive for loading.
- Conical bottom ensures smooth abrasive flow and complete emptying.
- Large inspection door for access to the interior.
- Wear-resistant urethane-coated pop-up valve seals tight and lasts longer.

BLAST MACHINES FOR INDUSTRIAL APPLICATIONS

Stationary models are suitable for industrial use in blast rooms or for other applications requiring a large volume, yet economical, blast machine. Stationary machines adapt to fixed sites or to custom truck (or trailer) mounted systems.

Model 3680*
20 cubic foot capacity



125 psi Working Pressure.

1/2 cuft and 1 cuft systems include the Apollo 20 Supplied-Air Respirator



Clemco's smaller machines are light, transportable, and industrial quality.

Model 1028
1/2 cubic foot capacity

Model 1042
1 cubic foot capacity
Tall and slim, can be moved empty with ease from blast site to blast site.



Complete System
Clemco's fully equipped and accessorized systems offer everything needed to blast except air and abrasive.

Model 3661*
10 cubic foot capacity

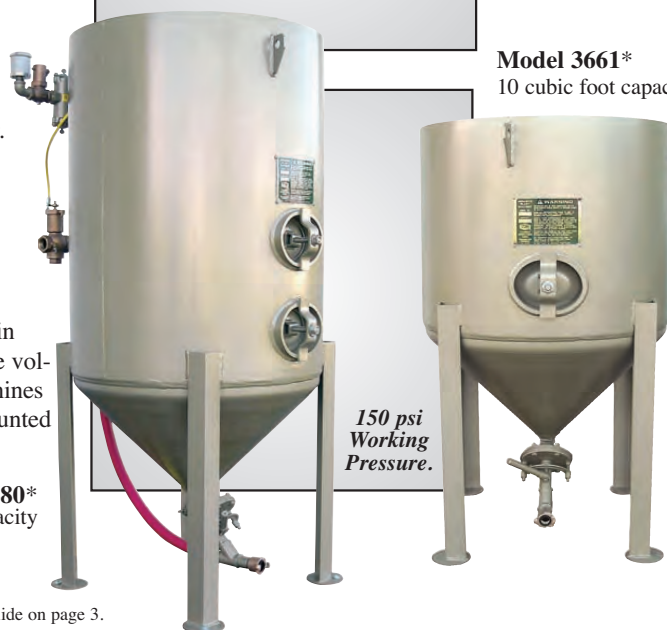

150 psi Working Pressure.

* Machines available with alternate metering valves. See application guide on page 3.

Blast Machines with a working pressure of 150 psi.



Decades of experience enable Clemco to produce blast machines suitable for a wide range of jobs.

Model 1642*
2 cubic foot capacity



Model 1648*
3 cubic foot capacity
A mid-size blast machine, a favorite of rental yards.



Model 2452*
6 cubic foot capacity
This larger capacity blast machine is the obvious choice for professional blasting contractors, shipyards, railcar re-man facilities and large scale industrial production.



Model 3054*
7 cubic foot capacity



Model 2463*
8 cubic foot capacity
Dual blast chambers permit continuous blasting. The 8 cuft machine can be equipped with twin outlets allowing two operators to work without interruption.



Model 2443
6 cubic foot capacity
Lo-Pot Blast Machines are designed for ease in abrasive loading.

Shown without OSHA required remote controls

* Machines available with alternate metering valves. See application guide on page 3.

Remote Controls — *Critical Operator Safety Accessory*

OSHA's requirements for remote-controlled blasting safety lie at the heart of Clemco Remote Control Systems:

"Abrasive blast cleaning nozzles shall be equipped with an operating valve which must be held open manually..." OSHA 1926.302 (b) (10) and 29CFR 1910.244 (b)

"A 'deadman' control device shall be provided at the nozzle end of the blasting hose ...to provide direct cut-off (of abrasive to the blast hose) in the event the blaster loses control of the hose..." OSHA 1915.34 (c) (1) (iv)

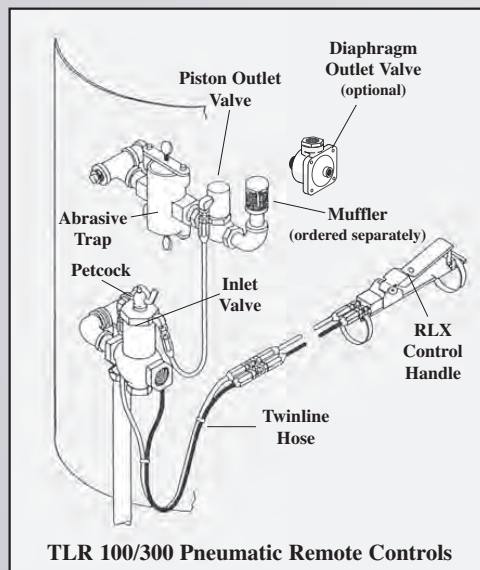

The Clemco **TLR 100 and 300 pressure-release pneumatic systems** operate on the return-air principle. A handle installed at the nozzle connects pneumatically to inlet and outlet valves on the blast machine. With the safety petcock on the inlet valve closed, the operator depresses the handle which opens the inlet valve and closes the outlet to start blasting; releasing the handle reverses the process and blasting stops. This safety system stops blasting should the operator lose control of the nozzle. And when the blast session is over, the safety petcock is opened to prevent activation, even when the handle is depressed. The diaphragm outlet valve is recommended for aggressive or fine-mesh abrasive applications.

TLR 50 for 1/2-inch piped machines operates similarly but is not shown.

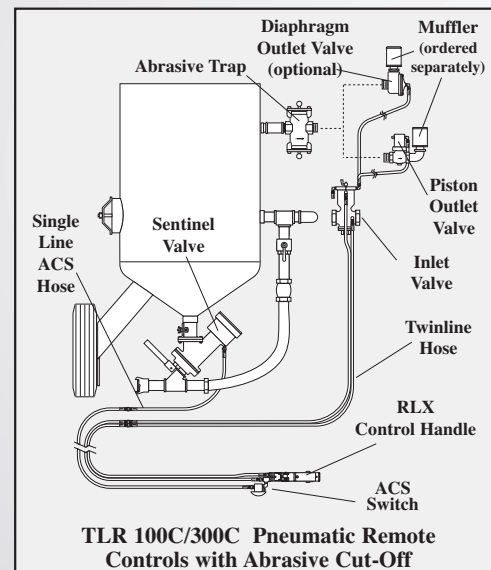

The Clemco **TLR 100C and 300C pressure-release pneumatic systems** feature an abrasive cut-off system (ACS), which permits the operator to shut-off the abrasive flow for clearing the blast hose and for blowing down the surface after blasting. These remote control systems include inlet and outlet valves, abrasive trap, self-cleaning muffler that reduces air exhaust noise, and the air-operated normally-closed Sentinel abrasive metering valve.



Apart from respiratory protection, the most important blasting safety accessory is the remote control. All Clemco remote control systems meet the OSHA requirements for remote-controlled blasting.



Clemco's RLX remote control handle—
...the workhorse of the industry!

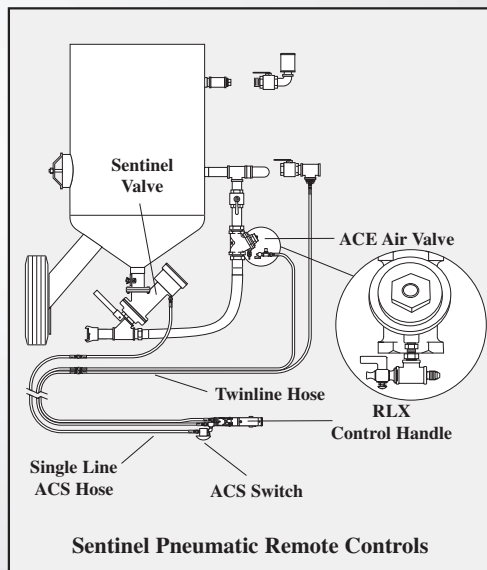

For applications that require frequent starts and stops, machines should be equipped with **Sentinel pressure-hold pneumatic remote controls**, which keep the blast machine under pressure but allow the operator to start and stop blasting as frequently as needed. The machine is pressurized and depressurized manually, and the remote control handle controls the on/off of the abrasive and air independently. These systems are available in pneumatic and electric models.

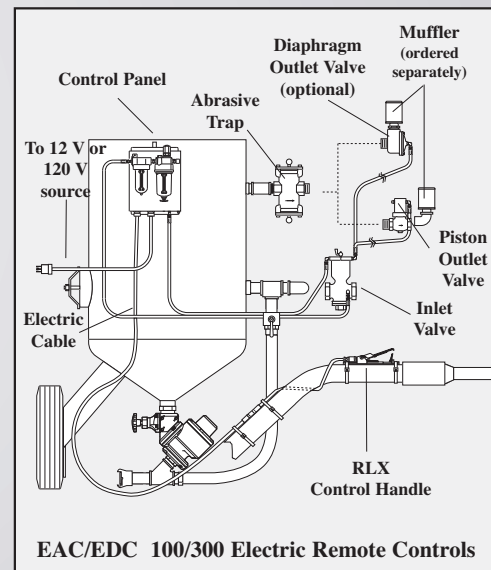

The Clemco **EAC 100/300 (AC electrics)** and **EDC 100/300 (DC electrics) pressure-release electric remote control systems** are available for extremely cold weather applications or where a continuous length of 100 feet or more of blast hose is used. An electric switch sends a signal through electric cord to open and close the inlet and outlet valves, avoiding the delay that would be experienced with air hose. Electric systems feature an anti-freeze injector accessory, which is optional on pneumatic systems. Electric remotes operate on a compressor's 12-volt system or 120-volt line power. Only 12-volt power reaches the handle for the safety of the operator. The diaphragm outlet valve is an option with the EAC/EDC remotes and is recommended for aggressive or fine-mesh abrasive applications.



SPECIFICATIONS

Table with 10 columns: Model, Dimensions Dia x Height, Standard Working Pressure, Capacity Cu Ft., Portable or Stationary, Piping (I.D.), ACS Option, Remote Controls Pneu. or Elec., Metering Valve, Pop-up Valve & O-ring. Rows include models 1028, 1042, 1642, 1648, 2443, 2452, 2463, 3054, 3079, 3661, 3680.

NOTES:

** 10 cu. ft. machines manufactured before 1983 use different pop-up valve and seat. Consult your Clemco distributor for details. MSV, FSV, and LPV abrasive metering valves are suitable for blasting with mineral and slag expendable media. The Quantum and Sentinel metering valves handle all common media including steel grit. ACS is an optional accessory for TLR pressure release remotes with Sentinel metering valves and is standard on machines with Sentinel pressure hold remotes.

Remote Controls:

Remote control systems have valves matched in size to the blast machine piping. Remote control system styles vary to suit the blasting operation or application. Pneumatic remote controls work best with blast hose lengths up to 100 ft.; and Electric remotes, powered electro-pneumatically, are for hose lengths greater than 100 ft. TLR 100D, 300D, 100DC, and 300DC feature the diaphragm outlet valve. The diaphragm outlet valve is recommended when using aggressive abrasive or fine mesh abrasive (50 mesh or finer).

Table with 5 main columns: Machine, Pressure-Release, Pressure-Release w/ACS, Pressure-Hold, Pneumatic or Electric. Sub-columns include Piping Size, Pneumatic, Electric, and Sentinel Remote Controls.

Piping Size: Size varies with pressure vessel capacity. Choose larger diameter piping for high production operations.

Pressure-Release Remotes: Pressurize/depressurize machine by pressing/releasing handle — simplest system to operate.

Pressure-Release Remotes with Abrasive Cut-off: Allows the operator to stop the flow of abrasive to blow off the surface after blasting.

Pressure-Hold Remotes: Keep the blast machine under pressure for frequent starting and stopping.

ISO 9001:2008 certified. Clemco is committed to continuous product improvement. Specifications are subject to change without notice.

Distributed by: